



ISSN: 2350-0328

**International Journal of Advanced Research in Science,
Engineering and Technology**

Vol. 6, Issue 6, June 2019

Research to Improve the Design of the Node of the Saw Cylinder Gin

**Djurayev Anvar Djurayevich, Yunusov Salokhiddin Zununovich, Abduvakhidov
Mubosherkhon, Mirzaumidov Asilbek Shukhratjonovich**

Tashkent Institute of Textile and Light Industry,
Professor, Namangan Engineering and Technology Institute, Namangan State University

ABSTRACT: The article presents the results of a study to improve the design of the gin saw cylinder assembly by using the Coriolis inertia force to hold the fiber on the front face of the saw tooth, as well as the impulsive force generated by the tangential acceleration of the saw rotating with the variable frequency of the gin saw cylinder.

KEYWORDS: gin; saw cylinder; drive of the saw cylinder; gears; variable shaft speed; eccentric installation; support for absorbing vibrations; fixed elastic sleeves; truncated conical shape.

I. DESIGN FEATURES OF THE SAW CYLINDER GIN

The gin saw cylinder is designed to grip the volatile fiber from the saw teeth, tear it away from the seeds and carry it out through the gap gaps in the grate to the air collection device. In addition, simultaneously with the separation of the fiber, the saw cylinder, coming into contact with the raw roller in the arc of the capture of the fiber in the working chamber, rotates it, which creates conditions for the constant supply of fresh bats to the saw disks.

The following technological requirements are imposed on the saw cylinder: to ensure a given performance and uninterrupted rotation of the raw roller, the saw cylinder must have a high gripping capacity; saw blades must be firmly fixed on the shaft of the saw cylinder, do not change their position during operation. When rotating the cylinder, the saws should run strictly along the center of the gap between the grate bars.

By the number of saw blades on the shaft, the saw cylinders are divided into 80, 90 and 130-saw cylinders and cylinders with a large number of saws. At the same time, an increase in the number of saws over 90 requires a change in the size of the gin.

For modern saw cylinders, drives with individual asynchronous electric motors are used.

In fig. 1. shows the gin saw cylinder, which includes the saw shaft 1, saw blades 2, interdisc pads 3, washers 4, clamping nuts 5 - right and left. One end of the saw shaft is closed by a safety sleeve, and the second is connected to the motor shaft through a semi-rigid coupling. The groove, which includes the tongue of the saw blade, protects the saw from turning is cut along the entire working length of the shaft. In the middle of the working length of the shaft of the saw cylinder, a retaining washer is fitted, from which saw blades are placed in both directions.

Typically, the diameter of the new saw blade 320 mm; Calibrated interlayer strips with a diameter of 162 mm, which increase the rigidity of the saws, are installed between the discs, and the exact distance set between the saws is established.

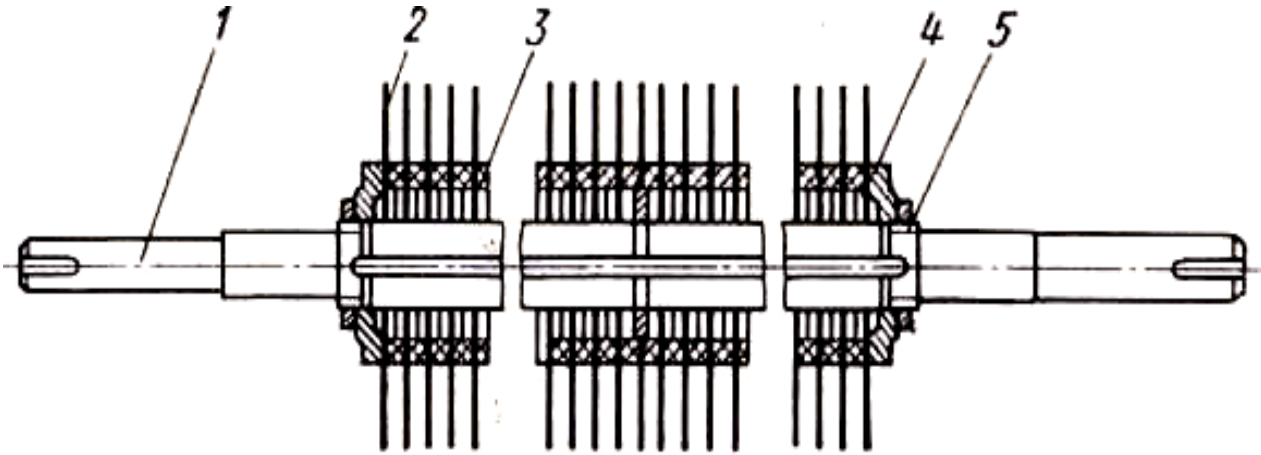
**Fig. 1. The design of the saw cylinder**

The deflection of the shaft of the saw cylinder is allowed to be no more than 0.3 - 0.4 mm and the face beating of the saws during rotation is not more than 0.15 mm, since otherwise the position of the saw changes in the gap gap between the grate bars, which causes damage to the fibers when they are dragging the teeth of the saws between the grate bars. The frequency of rotation of the saw shaft in the existing structures saw blades is 730 rev / min.

Let's analyze the features of some of the proposed designs of the gin saw cylinder

In fig. 2a is a cross-sectional view of the gin saw cylinder; and in fig. 2b is a fragment of a longitudinal section [1].

The saw cylinder (Fig. 1) contains a shaft 1 on which fixed keys 3 are mounted with the help of keys 2. A saw disk 4 and an annular element 5 are mounted on the annular protrusion of each strip. Elastic elements (springs 6) are located in arcuate through holes of the disks 4 and support grooves in the body gasket 3 and the annular element 5.

In the design of the saw cylinder (Fig. 2b), the axis of the coil spring 6 is located in the plane of the disk, and the center of the arc along which it is bent in the hole of the disk lies on the axis of the cylinder. The process of genie is as follows. When the raw roller comes in contact with the saw cylinder, the saw disks 4 capture the flying blades and move them into the ginning area. Due to the difference in density of the raw roller, the teeth of the saw disk 4 capture a different number of fibers and the fiber is pulled off with different forces leading to variable deformation of the springs 6 installed in the arcuate through holes of the middle part of the saw disk and in the bearing grooves between the gasket 3 and the ring element 5. When this occurs, high-frequency oscillations of the disks in the tangential direction, providing pulsed separation of the fiber from the seed, which leads to more efficient ginning and increased gin productivity. The arcuate shape of the holes centered on the axis of the cylinder to accommodate elastic elements contributes to an increase in the magnitude of the tangential acceleration when the disk oscillates.

The inclusion in the design of the cylinder of additional ring elements, freely mounted on the projections of the gaskets and fixed by elastic elements, allows the saw disk to perform autonomous tangential vibrations with the elimination of their axial displacement, which protects the disks from wear during the process of jining with possible contact with the grate and contributes increase reliability in the operation of the gin saw cylinder.

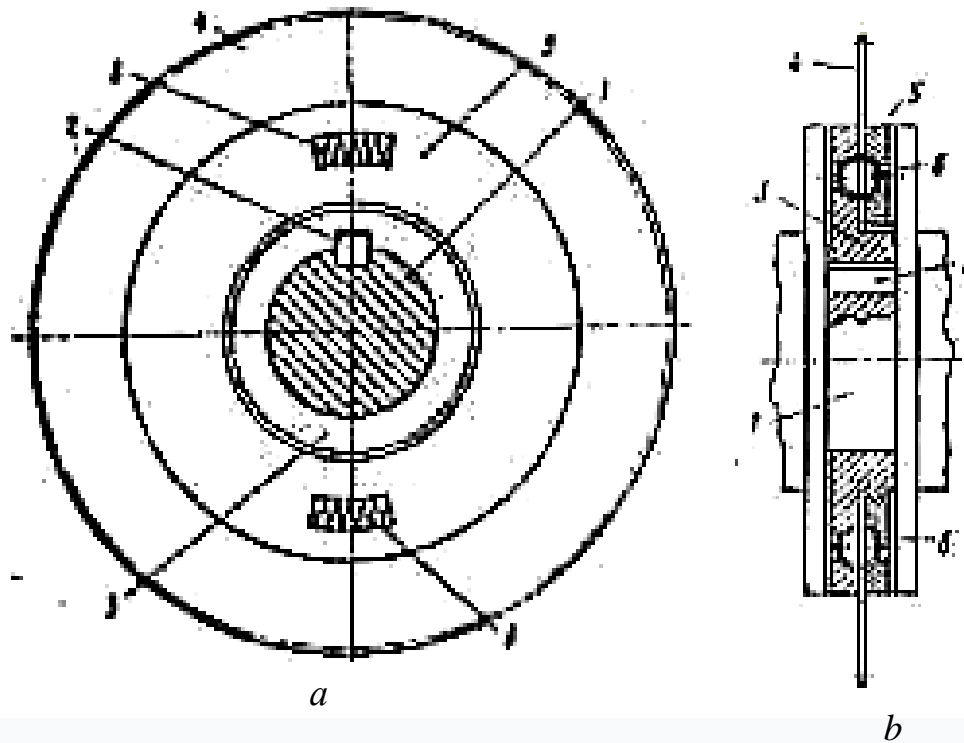

Fig.2. The construction of the gin saw cylinder

An analysis of the designs of the saw cylinders shows that the main direction of their improvement is based on an increase in the number of saws and an increase in the efficiency of ginning.

It is important to reduce the axial and polar moments of inertia of the elements of the saw cylinder, as well as constructive solutions aimed at increasing rigidity to bend the shaft, as well as to absorb and absorb oscillations of the saw cylinder due to elastic elements in the shaft bearings.

II. IMPROVING THE DESIGN OF THE SAW CYLINDER

In fig. 3a shows the proposed construction of the gin saw cylinder; in fig. 3b-interlayer pad with eccentricity [2].

The gin saw cylinder contains a shaft 1 with at least one key 2 located on its surface, saw disks 3 mounted on the shaft 1 and strips 4 between them.

Interdisable strips 4 are made eccentrically relative to the axis of rotation. At the same time, the eccentricities of adjacent interdisable strips 4 are phase-shifted by an angle of $2\pi/n$ (where $\pi = 3.14$ and n is the number of inter-core strips 4 on the saw cylinder). The proposed saw cylinder works as follows. When feeding the pulp, the saw blades 3 grab strands of cotton fibers and pull them over the grates, which oscillate in the radial direction due to the eccentricity of the pads 4. At the same time, the cotton fiber fibers easily detach from the seed due to the impact interaction of the seed with the gasket 4, i.e. increases the efficiency of ginning.

To ensure uniformity of fiber separation and eliminate the monotony of the process, the eccentricities of adjacent gaskets 4 are shifted by an angle of $2\pi/n$ (where n is the number of inter-layer gaskets). In addition, in the process of work, the bare seeds are quickly extracted and removed from the gin area due to additional vibrations

In fig. 4 shows another proposed scheme of the gin saw cylinder [3].

The gin saw drum contains a shaft 1 with at least one lug 2 located on its surface and 1 saw disks 3 assembled on the shaft.

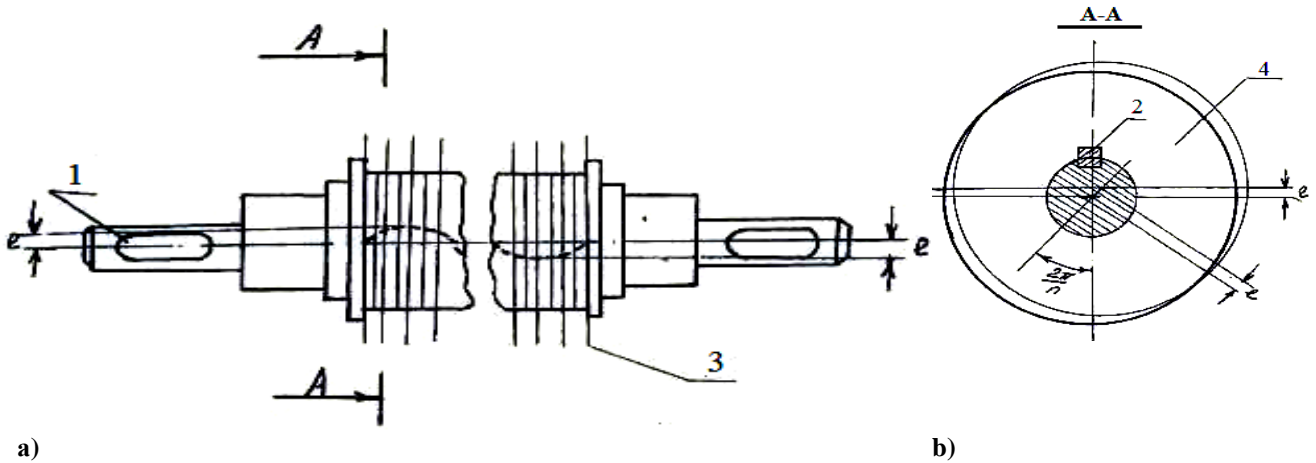

Fig. 3 gin saw cylinder
1-shaft, 2-key, 3-sawblade, 4-gasket.

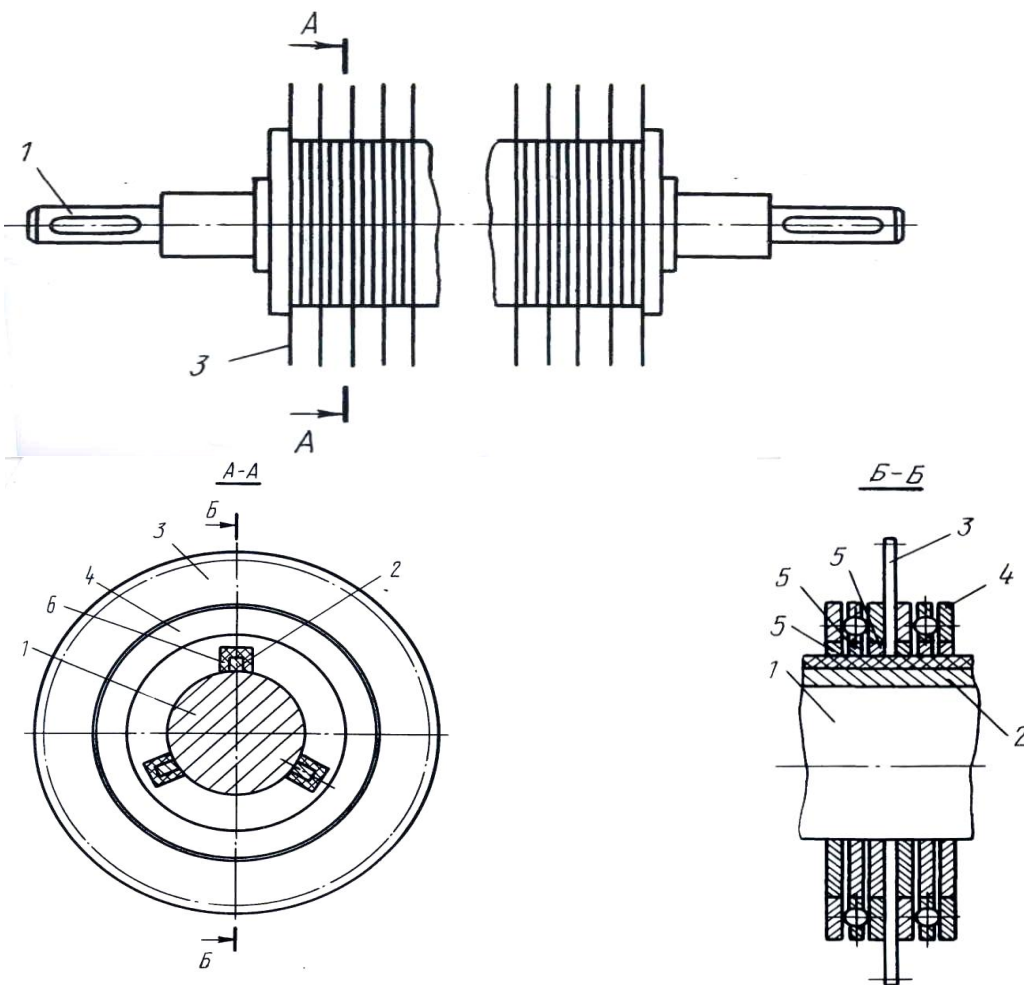

Fig. 4 gin saw cylinder
1-shaft, 2-protrusion, 3-saw disks, 4-bearing, 5-groove, 6- rubber coating, 7-holes.



ISSN: 2350-0328

International Journal of Advanced Research in Science, Engineering and Technology

Vol. 6, Issue 6, June 2019

Interdisposing gaskets are made in the form of thrust bearings 4 mounted on shaft 1 by means of bushing elements with profile grooves 5 corresponding to projections 2 of shaft 1 in shape and number. The means for creating angular movements of saw blades 3 is made in the form of a rubberized coating 6 located on a ledge 2 shaft 1. In the body of each saw blade 3, there are made through holes 7, which differ from the holes 7 of the adjacent disks 3 in size, number and configuration of relative position.

Saw drum fiber processing machine works as follows. When feeding the pulp, the saw disks 3 capture the strands of fibers and drag them along the grate, as a result of which the fiber is cleaned from weed impurities. Due to the presence of 3 through holes 7 on each saw blade, different from the holes 7 of adjacent drives 3 in size, number and configuration of relative position, the center of mass of each saw blade 3 shifts by a different value from the geometric axis of the shaft 1, as a result of which the saw the drum each saw blade 3 makes forced torsional vibrations of different amplitude and frequency.

As a result of this, additional impulses of force action arise on the strands of fibers trapped by the teeth of the saw blade 3, which leads to a more intensive release of trash. In fig. 5 shows the scheme of the proposed gin [4]. Gene contains horizontally located the saw cylinder 1, the working chamber formed by the frontal beam 2, grate 3, seed ridge 4, the lower apron 5 and the front apron 6, and the drive for the message to the saw cylinder rotation with variable frequency.

The drive contains gears 7 and 8 with eccentrically shifted centers. The process of genie is as follows. The saw blades of cylinder 1 receive rotation with variable frequency from a pair of eccentrically shifted gears 7 and 8. In this case, the teeth of the saw cylinder 1 capture the cotton fibers and separate them from the seed in the zone of the grate 3. It is known that the main force holding the fiber on the front face of the tooth is the friction force. In existing structures with a constant frequency of rotation of the saw cylinder, the force of friction depends mainly on the angle of the front face of the tooth and the weight of the fiber.

In the proposed design, the friction force of the fiber on the front face of the tooth increases due to the appearance of a Coriolis inertia force (or acceleration), which is directed along the normal perpendicular to the front face of the tooth; this force helps keep the fiber on the front face of the saw tooth. In addition, for the effective separation of the fiber from the seed, it is advisable to have impulsive force. This force occurs (due to tangential acceleration of the saw) only at a variable frequency of rotation of the cylinder.

Thus, telling the saw cylinder rotation with variable frequency, it is possible to achieve the efficiency of separation of seeds from the fibers due to the additional inertia of the movement of the saws. The proposed construction of the saw. Gin can significantly increase productivity.

The support for absorbing vibrations of rotating shafts (Fig. 6) includes a housing 1 in which a fixed elastic element in the form of a sleeve 2 is installed, made, for example, of round rubber, while the axis of the opening of the sleeve is offset relative to its central axis in the opposite direction the action of the resultant loading force on the value of not more than 15% of the inner radius of the sleeve. A bearing 3 is installed in the hole of the elastic element 2 (Fig. 6).

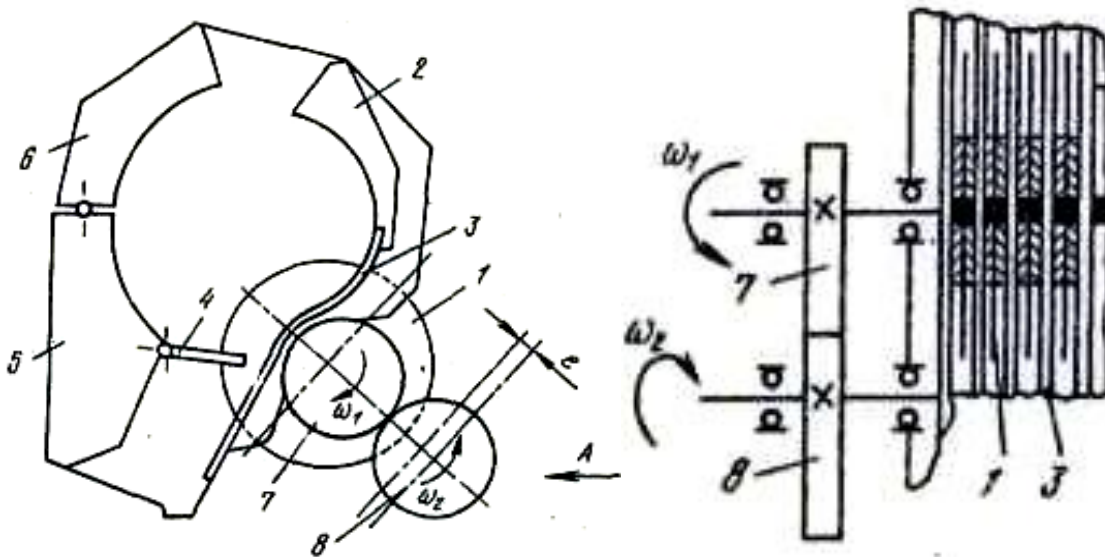

Fig. 5 saw gin

1-saw cylinder, 2-front bar, 3-grate, 4-seed comb, 5-bottom apron, 6-front apron, 7, 8-gear wheels.

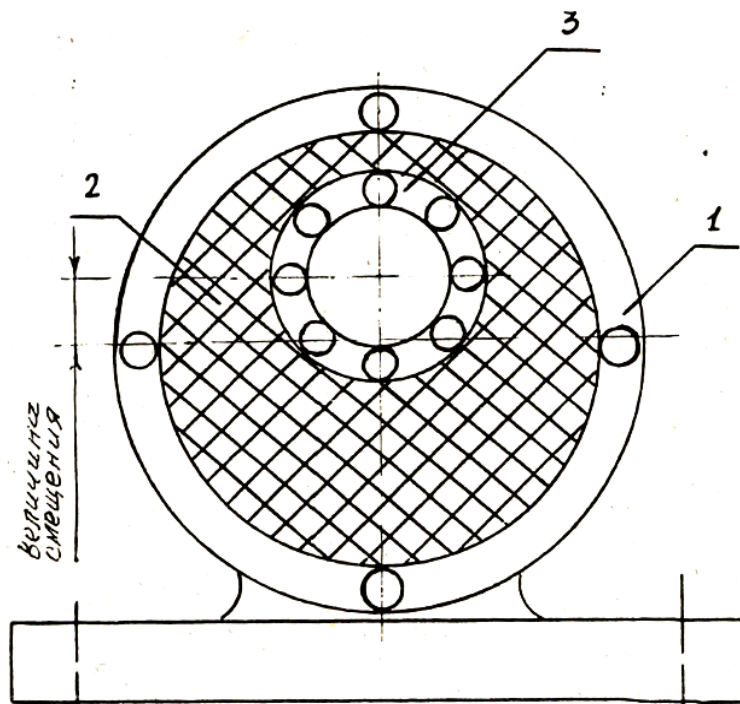

Fig. 6 Bearing support with elastic cushion for gin saw cylinder

1-body, 2-elastic cushion (sleeve), 3-bearing.

The following types of loads act on the rotating shaft (not shown in the figure): driving torque, gravity, inertial forces from unbalanced masses, friction forces, process loads, etc. and elastic element 2.

The presence of the elastic element 2 significantly reduces the effect of the above forces on the body 1. To reduce the effect of inertial forces on the body 1, respectively, select the necessary parameters that provide the elastic-dissipative properties of the elastic element. The displacement (eccentricity) of the axis of the elastic element made, for example, of rubber, coincides with the direction of the minimum load acting on the support from the imbalance of the shaft.

The use of this kind of shaft support will, due to the absorption of oscillations of rotating shafts, reduce the transmission of vibrations to the frames (housings) of the respective machines and mechanisms, therefore, the vibration noise characteristics of these machines and mechanisms will decrease to a great extent.

The proposed support can be recommended for use as a vibration-absorbing support in the main cotton preprocessing machines (cotton and fiber cleaners, separators, roller and saw ginters, etc.) mainly for the gin cylinder cylinder shaft bearing unit.

It is important to reduce the vibration of structural elements when external forces are applied to the shaft, both in the radial and axial directions. The problem is solved by improving the design of the shaft bearing unit with the elastic element. The essence of the design lies in the fact that the support for absorbing vibrations of the rotating shafts includes a housing with a bearing mounted in it and placed between its outer surface and the housing of an elastic element made in the form of a truncated conical sleeve. The truncated conical sleeve is made of rubber, while the base with the smaller diameter of the truncated conical bushings of the shaft supports is installed in the housing in opposite directions and is on the outside of the housing, and the bases with the larger diameter of elastic bushings are facing each other and are on the inside enclosures. The truncated conical shape of the elastic sleeves absorbs vibrations in the radial and axial directions.

The proposed design is illustrated in the drawing in Fig. 7, where the installation of the shaft on supports with truncated conical bushings is shown in fig. 8- type A.

The support for absorbing vibrations of the rotating shafts comprises a housing 1 in which fixed elastic sleeves 2, 3 of a truncated conical shape are installed. Elastic sleeves 2 and 3 are made of oil resistant rubber. The diameters d of the smaller bases of the elastic sleeves 2 and 3 are installed in the housing 1 in opposite directions and are on the outside of the housing 1. The diameters D of the large bases of the elastic sleeves 2 and 3 are installed in the housing 1 towards each other and are the inner side of the housing 1. In the holes of the elastic sleeves 2 and 3 mounted bearings 4, fixed on the shaft 5.

In the course of work, the following types of loads act on the rotating shaft: driving torque, gravity, inertia forces from unbalanced masses, friction forces, technological loads, etc. Components of the resultant force will be directed both in the radial and axial directions. These forces will act cyclically on the housing 1 through the bearing 4 and the elastic sleeves 2 and 3. The presence of elastic sleeves 2 and 3 significantly reduce the effect of these forces on the body 1,

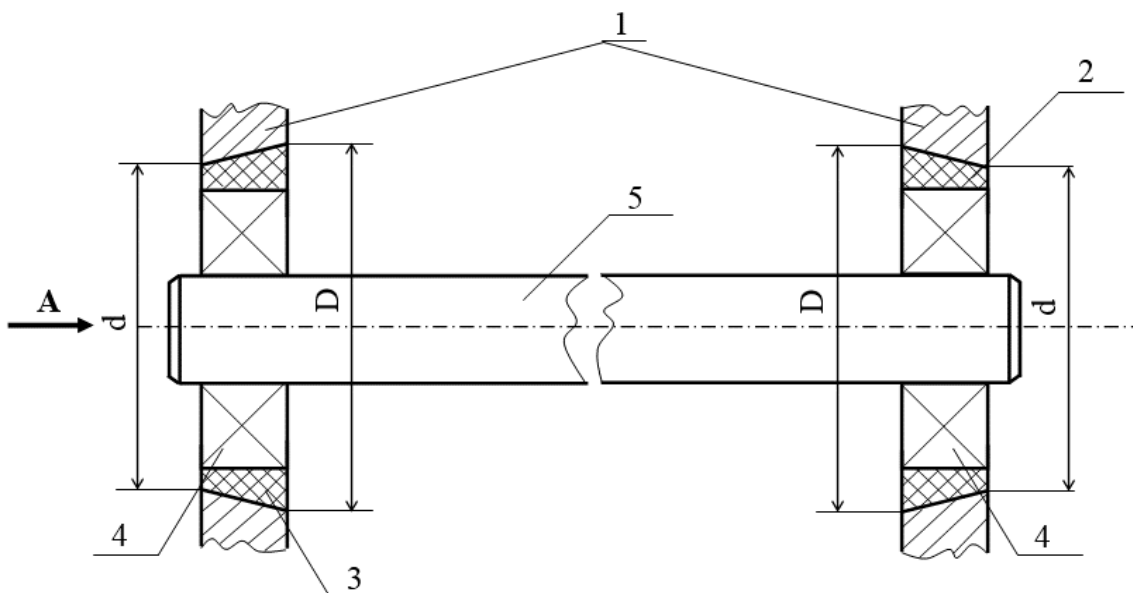
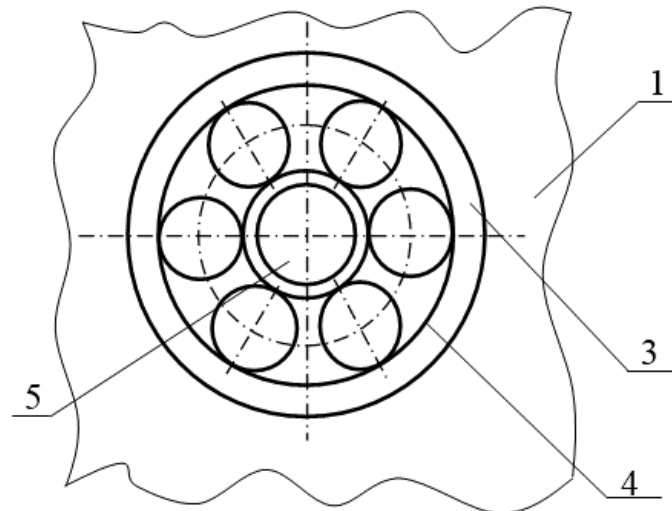

Fig. 7 Diagram of shaft installation on supports with truncated conical bushings
1- housing; 2,3- elastic sleeves; 4- bearings; 5-shaft

Fig.A



b)

Fig. 8. Support for the absorption of vibrations of rotating shafts, type A. 1- housing; 2,3- elastic sleeves; 4- bearing; 5- shaft

In which fixed elastic bushings 2, 3 of truncated conical shape are installed. Elastic sleeves 2 and 3 are made of oil resistant rubber. The diameters d of the smaller bases of the elastic sleeves 2 and 3 are installed in the housing 1 in opposite directions and are on the outside of the housing 1. The diameters D of the large bases of the elastic sleeves 2 and 3 are installed in the housing 1 towards each other and are the inner side of the housing 1. In the holes of the elastic sleeves 2 and 3 mounted bearings 4, fixed on the shaft 5.

The magnitude of the bending of the shaft 5 due to the radial components of the force is significantly reduced. The implementation of the elastic sleeves 2 and 3 in the form of a truncated cone with the diameters of the bases d and D allows you to absorb the axial components of the forces.

The use of this type of shaft support will, due to the absorption of oscillations of rotating shafts, reduce the transmission of vibrations to the frames (housings) of the respective machines and mechanisms, therefore, the vibration noise characteristics of these machines and mechanisms are reduced to a significant degree.

The proposed support can be recommended for use as a vibration-absorbing support in the main cotton preprocessing machines (cotton and fiber cleaners, separators, roller and saw ginters, etc.) and primarily for the gin cylinder shaft bearing unit.

III. THE CHOICE OF PARAMETERS OF THE ELASTIC BASE FOR THE BEARINGS OF THE SAW CYLINDER

Saw cylinders of gins are massive, their weight reaches half a ton [5]. During the rotation of the saw cylinder with a frequency of 730 rev / min due to unbalanced masses, as well as from cotton, captured by the teeth of the saw, there are significant centrifugal forces. When dragging 0.5 kg of cotton (fiber) at the same time by a saw cylinder rotating with a frequency of 730 rpm and a radius of 0.16 m, centrifugal force occurs:

$$P_u = m_x \cdot \left(\frac{\pi n_u}{30}\right)^2 \cdot \frac{D_u}{2} \quad (1)$$

where m_x - mass of simultaneously captured cotton (fibers); $n=730$ circle / min ; D_c - cylinder diameter

Moreover, their data $P_u=467$ H. This force, acting cyclically on the support cylinder, causes intense wear of bearings, which quickly fail. We have developed a design of the elastic base for bearings (Fig. 9) [6] to eliminate these effects.

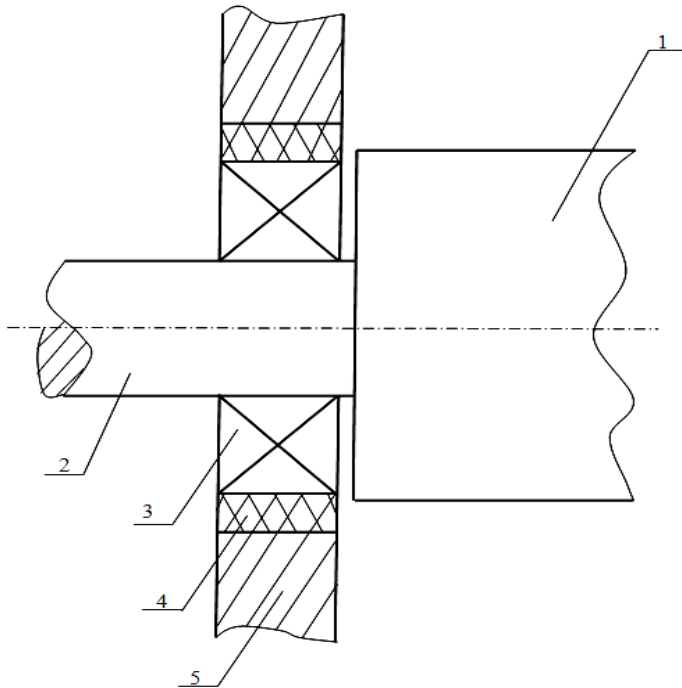

Fig. 9. Elastic bearing support of the saw cylinder
In fig. 9-saw cylinder 1; 2- shaft; 3-bearing; 4 - elastic sleeve; 5 - case

In fig. 9, the shaft 2 of the saw cylinder 1 is installed in the housing 5 by means of bearings 3 and an elastic sleeve 4. During operation of the saw cylinder, both in saw gins and cotton cleaners, the claws captured by the saw teeth are cotton (fibers) which is offset from the center of mass of the cylinder. [7]

In the static mode, the amount of deformation of the elastic supports (Fig. 9) under the bearings of the saw cylinder is determined from the expression:

$$a_{cm} = \frac{G_u}{2C_n} \quad (2)$$

where G_c – weight of the saw cylinder with bearings; C – support stiffness coefficient. In the process of work from an unbalanced mass of cotton (fiber) captured by the teeth of the cylinder saw, there is a centrifugal force:

$$P_c = m_x \omega_c^2 R_c \quad (3)$$

where m_x the mass of captured cotton (fiber) teeth saw; ω_c - saw head angle
; R_c – cylinder radius

While the amplitude of oscillation of the saw cylinder vertically according to (4) has the form:

$$a = \frac{a_{cm}}{\left| 1 - \frac{\omega_u^2}{P_0^2} \right|} \quad (5)$$

where $P_0 = \sqrt{\frac{C_c}{m_c + m}}$, m_c -cylinder mass

The amplitude of the reaction force of the bearings of the gin saw cylinder is proportional to the amplitude of the deformation of the elastic element:

$$R = C_c \cdot a = \frac{R}{\left|1 - \frac{\omega^2}{P_0^2}\right|} \quad (6)$$

Then the dynamic coefficient of the system is determined from the expression:

$$K = \frac{R}{R} = \frac{1}{\left|\frac{C_c - \omega^2(m_c + m_x)}{C_c}\right|} \quad (7)$$

Choosing the required parameter values C_c , ω_c , m_c и m You can control the value of the coefficient of dynamism. At the same time, choosing the required values of stiffness of the elastic support, the mass of the cylinder and the performance of the gin, it is possible to minimize (dampen) the oscillations of the saw cylinder in the vertical direction, which leads to an increase in the service life of bearings.

REFERENCES

1. Djurayev A SU 1513957A1, №2. 29.02.1988, Sawcylindergin.
2. Djurayev A PatentR.Uzb. IHDP 9900062.1, №4. 31.12.1999, Console grate of saw gin
3. PatentR.Uzb IHDP 9700041.1. Saw cylinder gin. Djurayev A. №2.30.06.1999.
4. RU 2023065C1. Saw drum fiber processing machine. Djurayev A. 15.11.1994
5. SU 1027295A. Saw gin. Djurayev A. №25.07.07.1983.
6. Patent IDP 04489. Support for swiveling vibrations of rotating shafts. Djurayev A. №5, 2000 г.
7. YunusovS..«Dynamics of machine units with mechanisms of saw gin working bodies». Monograph,« Fan va technology» Tashkent -2013.